



US 20140145157A1

(19) **United States**

(12) **Patent Application Publication**
Kim et al.

(10) **Pub. No.: US 2014/0145157 A1**
(43) **Pub. Date: May 29, 2014**

(54) **ORGANIC LIGHT EMITTING DIODE
DISPLAY DEVICE AND METHOD OF
FABRICATING THE SAME**

Publication Classification

(71) Applicant: **LG DISPLAY CO., LTD.**, Seoul (KR)

(51) **Int. Cl.**
H01L 27/32 (2006.01)

(72) Inventors: **Kang-Hyun Kim**, Gyeongju-si (KR);
Ki-Soub Yang, Paju-si (KR); **Dae-Jung
Choi**, Paju-si (KR); **Seung-Ryul Choi**,
Goyang-si (KR); **A-Ryoung Lee**, Seoul
(KR); **Han-Hee Kim**, Anseong-si (KR)

(52) **U.S. Cl.**
CPC **H01L 27/3246** (2013.01)
USPC **257/40**

(21) Appl. No.: **14/010,985**

(57) **ABSTRACT**

(22) Filed: **Aug. 27, 2013**

An organic light emitting diode display device includes a substrate including a display region, wherein a plurality of pixel regions are defined in the display region; a first electrode over the substrate and in each of the plurality of pixel regions; a first bank on edges of the first electrode and having a first width and a first thickness; a second bank on the first bank and having a second width smaller than the first width; an organic emitting layer on the first electrode and a portion of the first bank; and a second electrode on the organic emitting layer and covering an entire surface of the display region.

(30) **Foreign Application Priority Data**

Nov. 26, 2012 (KR) 10-2012-0134298

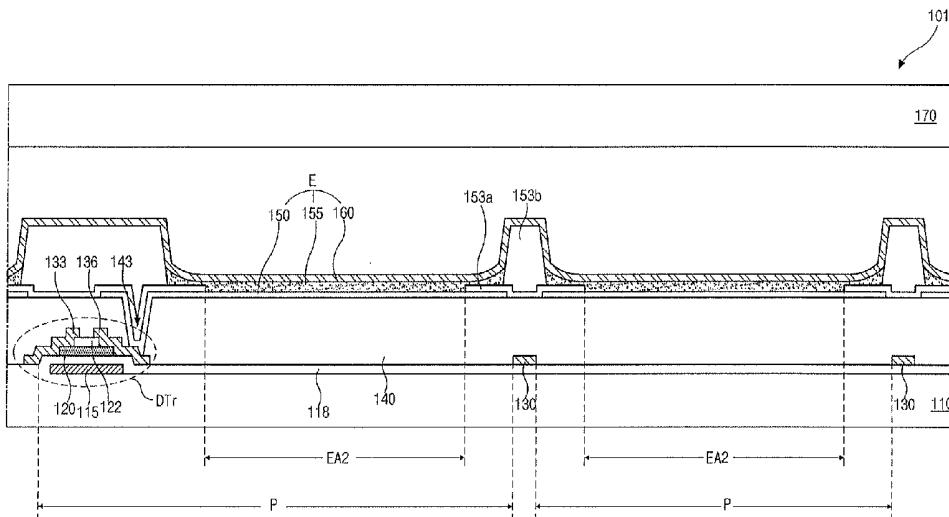

FIG. 1
Related Art

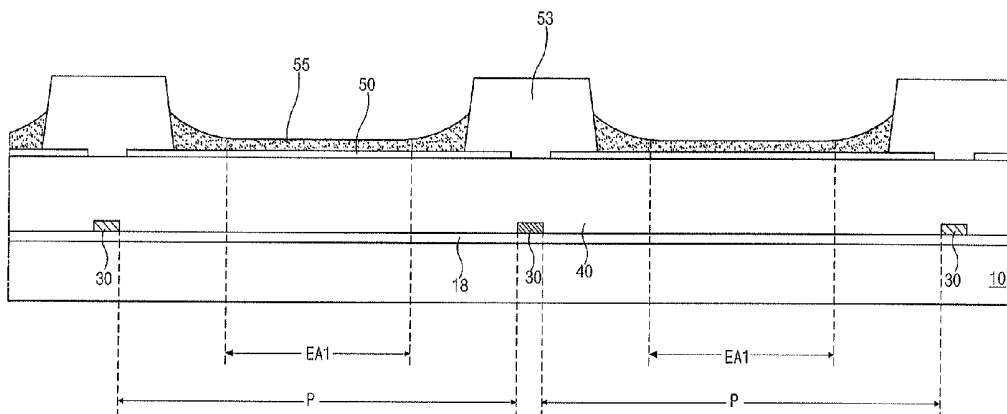

FIG. 2
Related Art

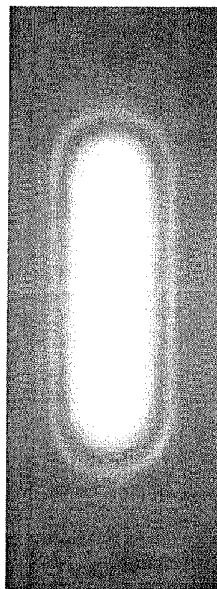

FIG. 3

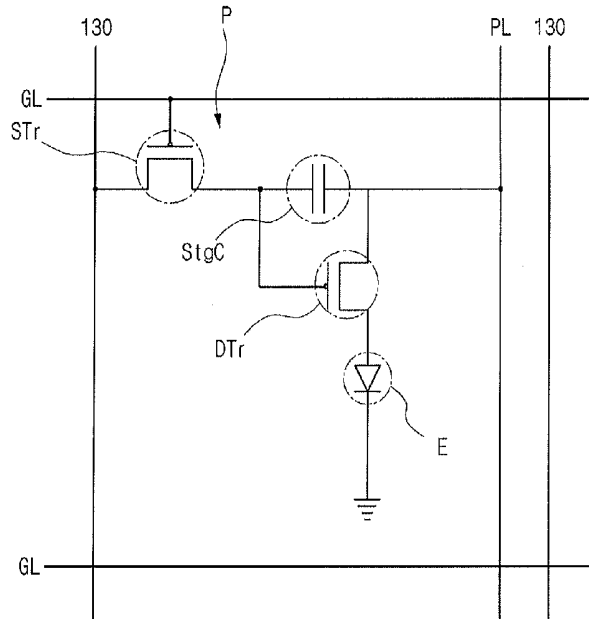

FIG. 4

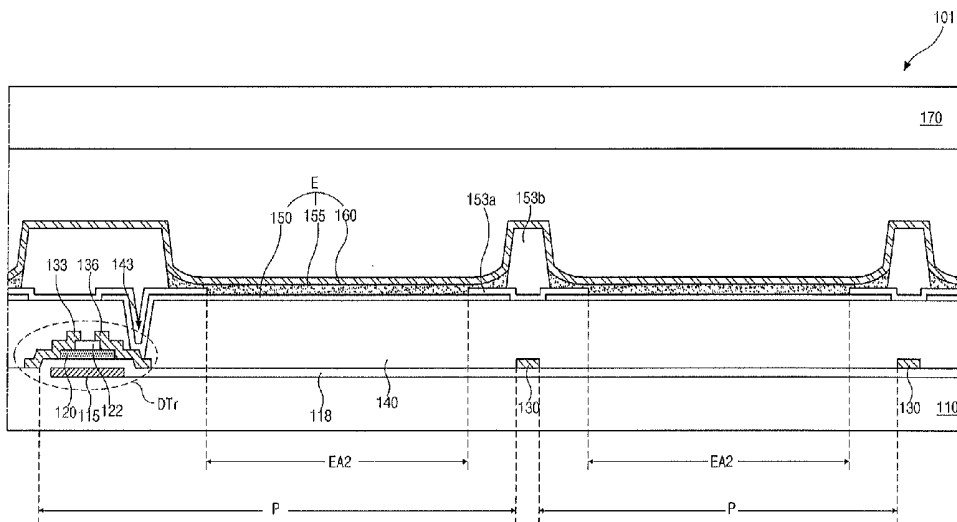

FIG. 5

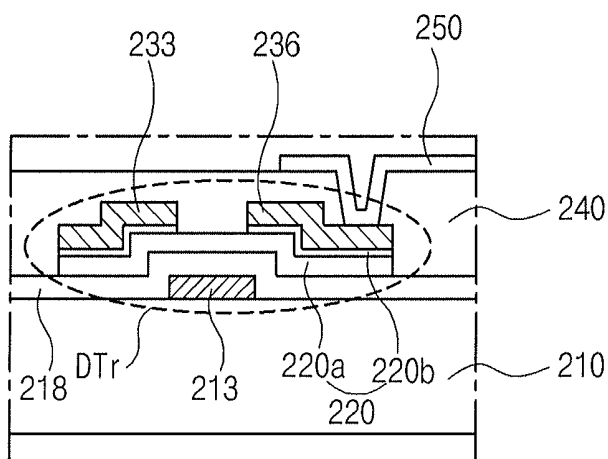

FIG. 6

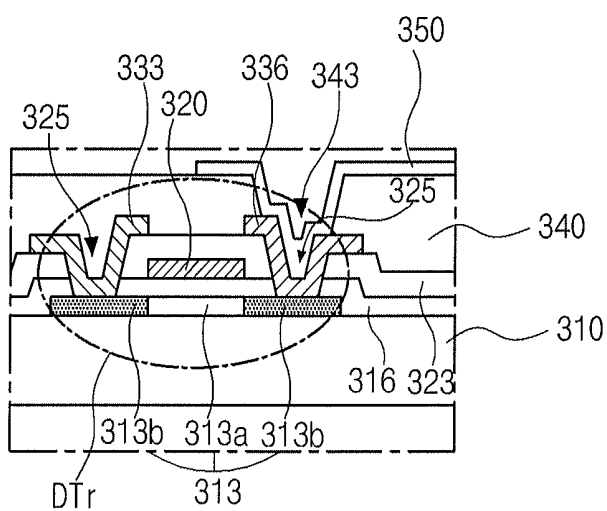

FIG. 7

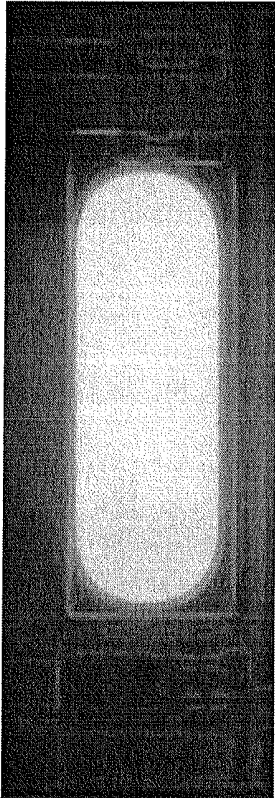
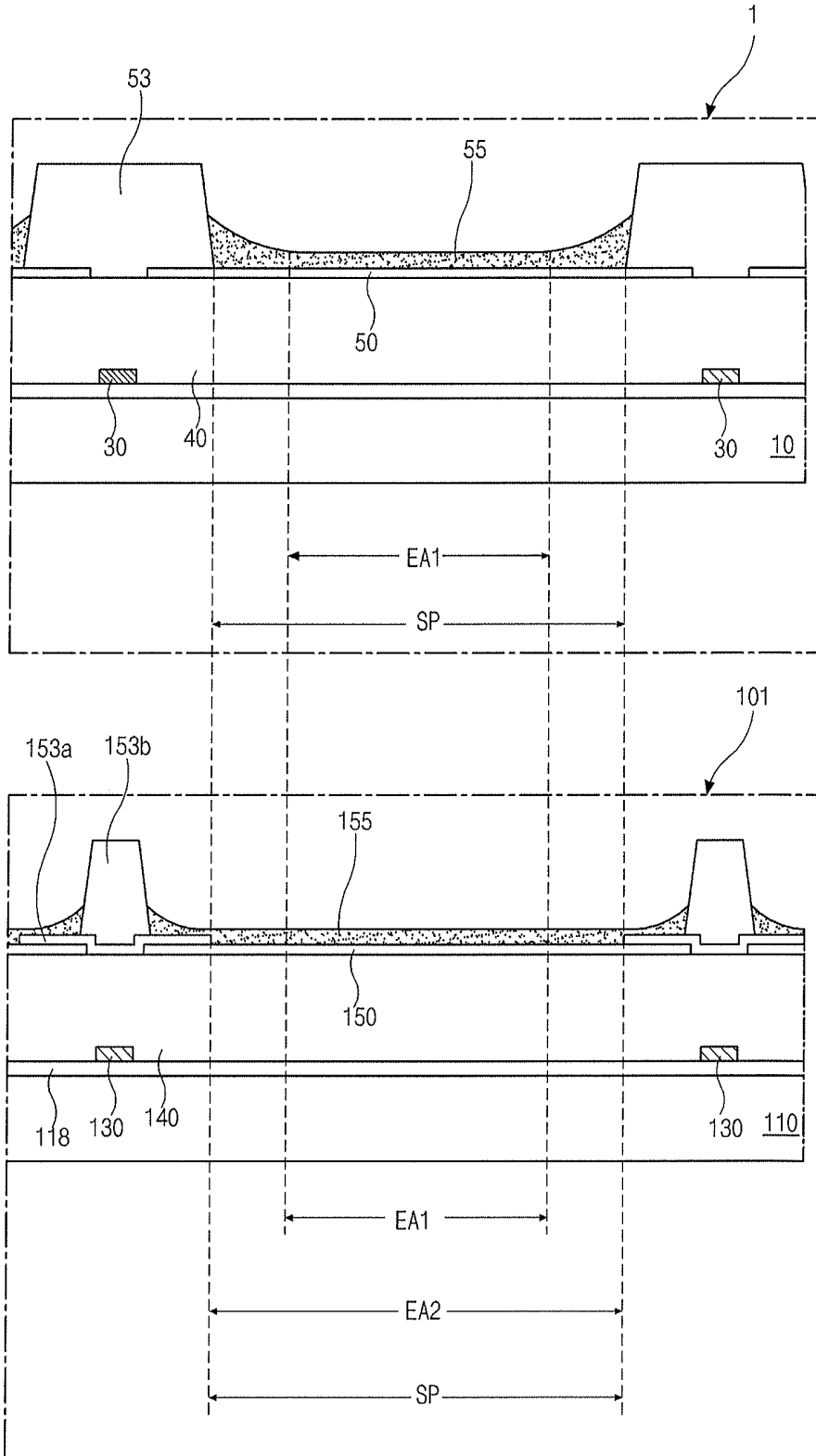

FIG. 8



**ORGANIC LIGHT EMITTING DIODE
DISPLAY DEVICE AND METHOD OF
FABRICATING THE SAME**

[0001] The present application claims the benefit of Korean Patent Application No. 10-2012-0134298 filed in Korea on Nov. 26, 2012, which is herein incorporated by reference in its entirety.

BACKGROUND

[0002] 1. Technical Field

[0003] The present disclosure relates to an organic light emitting diode (OLED) display device, and more particularly, to an OLED display device having improved aperture ratio and lifetime.

[0004] 2. Related Art

[0005] An OLED display device used in flat panel display devices has a high brightness and low driving voltage. The OLED display device is a self-emitting type and has excellent characteristics of a view angle, a contrast ratio, a response time and so on.

[0006] Accordingly, the OLED display device is being widely used for a television, a monitor, a mobile phone, and so on.

[0007] The OLED display device includes an array element and an organic light emitting diode. The array element includes a switching thin film transistor (TFT), which is connected to a gate line and a data line, a driving TFT, which is connected to the switching TFT, and a power line, which is connected to the driving TFT. The organic light emitting diode includes a first electrode, which is connected to the driving TFT, and an organic emitting layer and a second electrode. In the OLED display device, light from the organic emitting layer passes through the first electrode or the second electrode to display an image.

[0008] Generally, the organic emitting layer is formed by a thermal deposition using a shadow mask. However, the shadow mask sags because the shadow mask becomes larger with larger display devices. As a result, there is a problem in deposition uniformity in the larger display device. In addition, since a shadow effect is generated in the thermal deposition using the shadow mask, it is very difficult to fabricate a high resolution OLED display device, e.g., above 250 PPI (pixels per inch).

[0009] Accordingly, new method instead of the thermal deposition using the shadow mask is introduced.

[0010] In the new method, a liquid phase organic emitting material is sprayed or dropped in a region surrounded by a wall using an ink-jet apparatus or a nozzle-coating apparatus and cured to form the organic emitting layer.

[0011] FIG. 1 is a schematic cross-sectional view showing a step of forming an organic emitting layer by spraying or dropping a liquid phase organic emitting material.

[0012] To spray or drop the liquid phase organic emitting material by the ink-jet apparatus or the nozzle-coating apparatus, a bank **53**, which is formed on the first electrode **50** and surrounds a pixel region P is required to prevent the liquid phase organic emitting material from flooding into adjacent pixel region P. Accordingly, as shown in FIG. 1, the bank **53** is formed on edges of the first electrode **50** before forming the organic emitting layer **55**.

[0013] The bank **53** is formed of an organic material having a hydrophobic property. The hydrophobic bank **53** prevents

the organic emitting material, which has a hydrophilic property, from being formed on the bank **53** and flooding into adjacent pixel region P.

[0014] By spraying or dropping the liquid phase organic emitting material from a head of the ink-jet apparatus or a nozzle of the nozzle-coating apparatus into the pixel region P, which is surrounded by the bank **53**, the pixel region P is filled with the organic emitting material. The organic emitting material is dried and cured by a heat to form the organic emitting layer **55**.

[0015] However, the organic emitting layer **55** has a difference in a thickness. Namely, the organic emitting layer **55** has a thickness in edges being larger than a thickness in a center.

[0016] If the organic emitting layer **55** has a thickness difference, the OLED display device has a difference in emitting efficiency. Accordingly, as shown in FIG. 2, which is a picture showing one pixel region in the related art OLED display device, dark images are displayed in edges of the pixel region. In this instance, since the dark edges are perceived as an image defect by the viewer, the edges of the pixel region should be shielded such that the edges of the pixel region do not serve as an effective emitting area.

[0017] Referring again to FIG. 1, an effective emitting area EA1 is a portion of the pixel region P where the organic emitting layer **55** has a flat top surface. Namely, the aperture ratio of the OLED display device is decreased.

SUMMARY

[0018] An organic light emitting diode display device includes a substrate includes a display region, wherein a plurality of pixel regions are defined in the display region; a first electrode over the substrate and in each of the plurality of pixel regions; a first bank on edges of the first electrode and having a first width and a first thickness; a second bank on the first bank and having a second width smaller than the first width; an organic emitting layer on the first electrode and a portion of the first bank; and a second electrode on the organic emitting layer and covering an entire surface of the display region.

[0019] It is to be understood that both the foregoing general description and the following detailed description are exemplary and explanatory and are intended to provide further explanation of the invention as claimed.

BRIEF DESCRIPTION OF THE DRAWINGS

[0020] The accompanying drawings, which are included to provide a further understanding of the invention and are incorporated in and constitute a part of this specification, illustrate embodiments of the invention and together with the description serve to explain the principles of the invention.

[0021] FIG. 1 is a schematic cross-sectional view showing a step of forming an organic emitting layer by spraying or dropping a liquid phase organic emitting material.

[0022] FIG. 2 is a picture showing one pixel region in the related art OLED display device.

[0023] FIG. 3 is a circuit diagram of one sub-pixel region of an OLED device.

[0024] FIG. 4 is a schematic cross-sectional view of an OLED display device according to an embodiment of the present invention.

[0025] FIG. 5 is a schematic cross-sectional view of an OLED display device according to one modified embodiment of the present invention.

[0026] FIG. 6 is a schematic cross-sectional view of an OLED display device according to another modified embodiment of the present invention.

[0027] FIG. 7 is a picture showing one pixel region in an OLED display device according to the present invention.

[0028] FIG. 8 is a schematic cross-sectional view explaining effective emitting areas of the related art OLED display device and an OLED display device according to the present invention.

DETAILED DESCRIPTION

[0029] Reference will now be made in detail to the exemplary embodiments, examples of which are illustrated in the accompanying drawings.

[0030] FIG. 3 is a circuit diagram of one sub-pixel region of an OLED device.

[0031] As shown in FIG. 3, an OLED display device includes a switching thin film transistor (TFT) STr, a driving TFT DTr, a storage capacitor StgC and an emitting diode E in each pixel region P.

[0032] On a substrate (not shown), a gate line GL along a first direction and a data line 130 along a second direction are formed. The gate line GL and the data line 130 cross each other to define the pixel region P. A power line PL for providing a voltage to the emitting diode E is formed to be parallel to and spaced apart from the data line 130.

[0033] The switching TFT STr is connected to the gate and data lines GL and 130, the driving TFT DTr and the storage capacitor StgC are connected to the switching TFT STr and the power line PL. The emitting diode E is connected to the driving TFT DTr.

[0034] A first electrode of the emitting diode E is connected to a drain electrode of the driving TFT DTr, and a second electrode of the emitting diode E is grounded.

[0035] When the switching TFT STr is turned on by a gate signal applied through the gate line GL, a data signal from the data line 130 is applied to the gate electrode of the driving TFT DTr and an electrode of the storage capacitor StgC. When the driving TFT DTr is turned on by the data signal, an electric current is supplied to the emitting diode E from the power line PL. As a result, the emitting diode E emits light. In this case, when the driving TFT DTr is turned on, a level of an electric current applied from the power line PL to the emitting diode E is determined such that the emitting diode E can produce a gray scale. The storage capacitor StgC serves to maintain the voltage of the gate electrode of the driving TFT DTr when the switching TFT STr is turned off. Accordingly, even if the switching TFT STr is turned off, a level of an electric current applied from the power line PL to the emitting diode E is maintained to next frame.

[0036] FIG. 4 is a schematic cross-sectional view of an OLED display device according to an embodiment of the present invention. FIG. 4 shows one driving TFT DTr in one pixel region P. However, the driving TFT DTr is formed in each pixel region P.

[0037] As shown in FIG. 4, an OLED display device 101 of the present invention includes a first substrate 110, where a driving TFT DTr, a switching TFT (not shown) and an organic emitting diode E are formed, and a second substrate 170 for encapsulation. The second substrate 170 may be an inorganic insulating film or an organic insulating film.

[0038] A gate line (not shown) and a data line 130 are formed on the first substrate 110. The gate line and the data line 130 cross each other to define the pixel region P. A power

line (not shown) for providing a voltage to the emitting diode E is formed to be parallel to and spaced apart from the data line 130.

[0039] In each pixel region P, the switching TFT is connected to the gate line and the data line 130, and the driving TFT DTr and the storage capacitor StgC are connected to the switching TFT and the power line.

[0040] The driving TFT DTr includes a gate electrode 115, a gate insulating layer 118, an oxide semiconductor layer 120, an etch-stopper 122, a source electrode 133 and a drain electrode 136. The gate insulating layer 118 covers the gate electrode 115, and the oxide semiconductor layer 120 is disposed on the gate insulating layer 118. The oxide semiconductor layer 120 corresponds to the gate electrode 115. The etch-stopper 122 covers a center of the oxide semiconductor layer 120. The source electrode 133 and the drain electrode 136 are disposed on the etch-stopper 122 and spaced apart from each other. The source electrode 133 and the drain electrode 136 contact both ends of the oxide semiconductor layer 120, respectively. Although not shown, the switching TFT has substantially the same structure as the driving TFT DTr.

[0041] In FIG. 4, each of the driving TFT DTr and the switching TFT includes the oxide semiconductor layer 120 of an oxide semiconductor material. Alternatively, as shown in FIG. 5, each of the driving TFT DTr and the switching TFT may include a gate electrode 213, a gate insulating layer 218, a semiconductor layer 220 including an active layer 220a of intrinsic amorphous silicon and an ohmic contact layer 220b of impurity-doped amorphous silicon, a source electrode 233 and a drain electrode 236.

[0042] In addition, each of the driving TFT DTr and the switching TFT may have a top gate structure where the semiconductor layer is positioned at a lowest layer. Namely, as shown in FIG. 6, each of the driving TFT DTr and the switching TFT may include a semiconductor layer 313, which includes an active region 313a of intrinsic poly-silicon and impurity-doped regions 313b at both sides of the active region 313a, on a first substrate 310, a gate insulating layer 316, a gate electrode 320 corresponding to the active region 313a of the semiconductor layer 313, an interlayer insulating layer 323 having semiconductor contact holes 325, which expose the impurity-doped regions 313b of the semiconductor layer 313, and source and drain electrodes 333 and 336 respectively connected to the impurity-doped regions 313b through the semiconductor contact holes 325.

[0043] The top gate structure TFT requires the interlayer insulating layer 323 in comparison to a bottom gate structure TFT. In the top gate structure TFT, the gate line is formed on the gate insulating layer 316, and the data line is formed on the interlayer insulating layer 323.

[0044] Referring again to FIG. 4, a passivation layer 140, which includes a drain contact hole 143 exposing the drain electrode 136 of the driving TFT DTr, is formed over the driving TFT DTr and the switching TFT. For example, the passivation layer 140 may be formed of an organic insulating material, e.g., photo-acryl, to have a flat top surface.

[0045] A first electrode 150, which contacts the drain electrode 136 of the driving TFT DTr through the drain contact hole 143, is formed on the passivation layer 140 and separately in each pixel region P.

[0046] The first electrode 150 is formed of a conductive material having a relatively high work function, e.g., about 4.8 to 5.2 eV. For example, the first electrode 150 may be

formed of a transparent conductive material such as indium-tin-oxide (ITO) to serve as an anode.

[0047] When the first electrode **150** is formed of the transparent conductive material, a reflection layer (not shown) may be formed under the first electrode **150** to increase emission efficiency in a top emission type OLED display device. For example, the reflection layer may be formed of a metallic material, such as aluminum (Al) or Al alloy (AlNd), having a relatively high reflectivity.

[0048] With the reflection layer, the light from the organic emitting layer **155**, which is formed on the first electrode **150**, is reflected by the reflection layer such that the emission efficiency is increased. As a result, the OLED display device has an improved brightness property.

[0049] A first bank **153a** having a first width is formed along boundaries of the pixel region P. Namely, the first bank **153a** is formed on edges of the first electrode **150** such that a center of the first electrode **150** is exposed by the first bank **153a**. The first bank **153a** includes a hydrophilic material. For example, the first bank **153a** may be formed of an inorganic insulating material. Particularly, the first bank **153a** may be formed of at least one of silicon oxide or silicon nitride. A thickness of the first bank **153a** is smaller than that of the organic emitting layer **155**. The thickness of the first bank **153b** may have a range within about 0.2 to 1.5 micrometer.

[0050] In addition, a second bank **153b** is formed on the first bank **153a**. The second bank **153b** has a second width smaller than the first width of the first bank **153a** and completely overlaps the first bank **153a**. As a result, the first bank **153a** protrudes from the second bank **153b** by a width within about 1 to 9 micrometer. In other words, edges of the first bank **153a** are exposed by the second bank **153b**. The first width of the first bank **153a** is substantially the same as the bank **53** in the related art OLED display device.

[0051] The second bank **153b** includes an organic insulating material having a hydrophobic property. Namely, the second bank **153b** is formed of an organic insulating material having a hydrophobic property or an organic insulating material containing a hydrophobic material. For example, the second bank **153b** may be formed of at least one of polyimide containing fluorine (F), styrene, methylmethacrylate, polytetrafluoroethylene, such as Teflon.

[0052] In the OLED display device **101** including the first bank **153a**, which has the first width and the thickness being smaller than the organic emitting layer **155**, and the second bank **153b** having the second width being smaller than the first width of the first bank **153a**, the organic emitting layer **155** is formed on the first bank **153a** and the organic emitting material is concentrated into a center of the pixel region P by the first bank **153a**. As a result, a problem of increase of a thickness of the organic emitting layer **155** in a region adjacent to the first bank **153a** is reduced.

[0053] In addition, since the first bank **153a** has substantially the same width as the bank **53** (of FIG. 1), a region surrounded by the second bank **153b**, which has a second width smaller than the first bank **153a**, is larger than that surrounded by the bank **53**.

[0054] Moreover, since the first bank **153a** has the thickness smaller than the organic emitting layer **155**, the organic emitting layer **155** is formed on the first bank **153a**.

[0055] Furthermore, since the organic emitting layer **155** on the first bank **153a** has a portion forming substantially flat top surface with the center of the pixel region P, the organic

emitting layer **155** has the flat top surface in a region surrounded by the first bank **153a**.

[0056] Accordingly, an emitting area EA2, which is defined as a region of the organic emitting layer having the flat top surface, is increased in comparison to the emitting area EA1 (of FIG. 1) in the related art OLED display device such that the OLED display device of the present invention has improved aperture ratio.

[0057] Referring to FIG. 7, which is a picture showing one pixel region in an OLED display device according to the present invention, the emitting area EA2 (of FIG. 4) in the OLED display device of the present invention is increased in comparison to the emitting area EA1 (of FIG. 1) in the related art OLED display device. In addition, brightness uniformity of the OLED display device of the present invention is improved.

[0058] FIG. 8 is a schematic cross-sectional view explaining effective emitting areas of the related art OLED display device and an OLED display device according to the present invention.

[0059] With the size pixel region, an effective pixel region SP is defined as a region surrounded by the bank. In this instance, referring to FIG. 8, the effective pixel region SP in the related art OLED display device is a region surrounded by the bank **53**, while the effective pixel region SP in the OLED display device of the present invention is a region surrounded by the first bank **153a**. The area of the effective pixel regions SP in the related art OLED display device and the OLED display device of the present invention is equal.

[0060] However, an area of the effective emitting area EA2 in the effective pixel region SP of the OLED display device of the present invention is larger than that of the effective emitting area EA1 in the effective pixel region SP of the related art OLED display device.

[0061] Since the organic emitting layer **55** has a thickness difference in the edges of the effective pixel region SP, the effective emitting area EA1 is smaller than the effective pixel region SP. However, since the organic emitting layer **155** has a thickness uniformity in an entire surface of the effective pixel region SP, the effective emitting area EA2 is equal to the effective pixel region SP. Namely, an area of the effective emitting area EA2 in the effective pixel region SP of the OLED display device of the present invention is larger than that of the effective emitting area EA1 in the effective pixel region SP of the related art OLED display device such that the aperture ratio of the OLED display device is increased.

[0062] Referring again to FIG. 4, the organic emitting layer **155** is formed on the first electrode **150** and in an opening of the second bank **153b**. The organic emitting layer **155** includes red, green and blue emitting material in each pixel region P.

[0063] The organic emitting layer **155** is formed by forming an organic emitting material layer and curing the organic emitting material layer. The organic emitting material layer is formed by coating, i.e., spraying or dropping a liquid phase organic material by an ink-jet apparatus or a nozzle-coating apparatus.

[0064] FIG. 4 shows a single-layered organic emitting layer **155**. Alternatively, to improve emission efficiency, the organic emitting layer **155** may have a multi-layered structure. For example, the organic emitting layer **155** may include a hole injecting layer, a hole transporting layer, an emitting material layer, an electron transporting layer and an electron injecting layer stacked on the first electrode **150** as an anode.

The organic emitting layer **155** may be a quadruple-layered structure of the hole transporting layer, the emitting material layer, the electron transporting layer and an electron injecting layer or a triple-layered structure of the hole transporting layer, the emitting material layer and the electron transporting layer.

[0065] A second electrode **160** is formed on the organic emitting layer **155** and covers an entire surface of a display region of the first substrate **110**. The second electrode **160** is formed of a metallic material having a relatively low work function, e.g., Al, Al alloy, silver (Ag), magnesium (Mg), gold (Au), Al—Mg alloy (AlMg). The second electrode **160** serves as a cathode. In the top emission type OLED display device, the second electrode **160** has a transparent property. On the other hand, in a bottom emission type OLED display device, the second electrode **160** has a reflective property.

[0066] The first electrode **150**, the organic emitting layer **155** and the second electrode **160** constitute the emitting diode E.

[0067] A seal pattern (not shown) of a sealant or a frit material is formed on edges of the first substrate **110** or the second substrate **170**. The first and second substrates **110** and **170** are attached using the seal pattern. A space between the first and second substrates **110** and **170** has a vacuum condition or an inert gas condition. The second substrate **170** may be a flexible plastic substrate or a glass substrate.

[0068] Alternatively, the second substrate **170** may be a film contacting the second electrode **160**. In this instance, the film-type second substrate is attached to the second electrode **160** by an adhesive layer.

[0069] In addition, an organic insulating film or an inorganic insulating film may be formed on the second electrode **160** as a capping layer. In this instance, the organic insulating film or the inorganic insulating film serves as the encapsulation film without the second substrate **170**.

[0070] In the OLED display device **101** including the first bank **153a**, which has the thickness being smaller than the organic emitting layer **155**, and the second bank **153b** having the second width being smaller than the first width of the first bank **153a**, the organic emitting layer **155** is formed on the first bank **153a** and the organic emitting material is concentrated into a center of the pixel region P by the first bank **153a**. As a result, a problem of increase of a thickness of the organic emitting layer **155** in a region adjacent to the first bank **153a** is reduced.

[0071] In addition, since the organic emitting layer **155** on the first bank **153a** has a portion forming substantially flat top surface with the center of the pixel region P, the organic emitting layer **155** has a uniform thickness in a region surrounded by the first bank **153a**. As a result, an emitting area EA2 is increased in comparison to the emitting area EA1 (of FIG. 1) in the related art OLED display device such that the OLED display device of the present invention has improved aperture ratio.

[0072] Moreover, since an area having thickness uniformity of the organic emitting layer **155** is increased, brightness uniformity of the OLED display device of the present inven-

tion is improved. Furthermore, due to the thickness uniformity of the organic emitting layer **155**, a thermal degradation problem of the organic emitting layer is prevented such that the OLED display device has an improved lifetime.

[0073] It will be apparent to those skilled in the art that various modifications and variations can be made in the present invention without departing from the spirit or scope of the invention. Thus, it is intended that the present invention cover the modifications and variations of this invention provided they come within the scope of the appended claims and their equivalents.

What is claimed is:

1. An organic light emitting diode display device, comprising:

a substrate including a display region, wherein a plurality of pixel regions are defined in the display region;
a first electrode over the substrate and in each of the plurality of pixel regions;
a first bank on edges of the first electrode and having a first width and a first thickness;
a second bank on the first bank and having a second width smaller than the first width;
an organic emitting layer on the first electrode and a portion of the first bank; and
a second electrode on the organic emitting layer and covering an entire surface of the display region.

2. The device according to claim 1, wherein the first bank includes a material having a hydrophilic property, and the second bank includes a material having a hydrophobic property.

3. The device according to claim 2, wherein the first bank is formed of at least one of silicon oxide and silicon nitride.

4. The device according to claim 2, wherein the second bank is formed of at least one of polyimide containing fluorine (F), styrene, methylmethacrylate, and polytetrafluoroethylene.

5. The device according to claim 1, wherein the organic emitting layer on the portion of the first bank has a flat top surface with the organic emitting layer on a center of the pixel region.

6. The device according to claim 1, wherein the organic emitting layer in a region surrounded by the first bank has a uniform thickness.

7. The device according to claim 1, wherein the organic emitting layer has a second thickness larger than the first thickness.

8. The device according to claim 7, wherein the first thickness has a range within about 0.2 to 1.5 micrometer.

9. The device according to claim 1, wherein the second bank completely overlaps the first bank such that the first bank protrudes from the second bank by a third width.

10. The device according to claim 9, wherein the third width has a range within about 1 to 9 micrometer.

11. The device according to claim 1, further comprising a thin film transistor in each pixel region, wherein the first electrode is connected to the thin film transistor.

* * * * *

专利名称(译)	有机发光二极管显示装置及其制造方法		
公开(公告)号	US20140145157A1	公开(公告)日	2014-05-29
申请号	US14/010985	申请日	2013-08-27
[标]申请(专利权)人(译)	乐金显示有限公司		
申请(专利权)人(译)	LG DISPLAY CO. , LTD.		
当前申请(专利权)人(译)	LG DISPLAY CO. , LTD.		
[标]发明人	KIM KANG HYUN YANG KI SOUB CHOI DAE JUNG CHOI SEUNG RYUL LEE A RYOUNG KIM HAN HEE		
发明人	KIM, KANG-HYUN YANG, KI-SOUB CHOI, DAE-JUNG CHOI, SEUNG-RYUL LEE, A-RYOUNG KIM, HAN-HEE		
IPC分类号	H01L27/32		
CPC分类号	H01L27/3246		
优先权	1020120134298 2012-11-26 KR		
其他公开文献	US9231035		
外部链接	Espacenet USPTO		

摘要(译)

一种有机发光二极管显示装置，包括：基板，包括显示区域，其中，多个像素区域限定在显示区域中；基板上方和多个像素区域中的每个像素区域中的第一电极；第一电极边缘的第一堤岸，具有第一宽度和第一厚度；第一排上的第二排，其第二宽度小于第一宽度；第一电极上的有机发光层和第一堤的一部分；第二电极位于有机发光层上并覆盖显示区域的整个表面。

